



2" BORE ACCESSORIES



MOUNTING NUTS

Stud Nut

Part Number	Across Flats	Nut Thickness	Nut (Thread)
N20-12	1 3/4"	7/16"	1 1/4-12

Rod Nut

Part Number	Across Flats	Nut Thickness	Nut (Thread)
N08-20	3/4"	5/16"	1/2-20

CB-3295

Clevis Bracket
Material: Steel, bright zinc plated

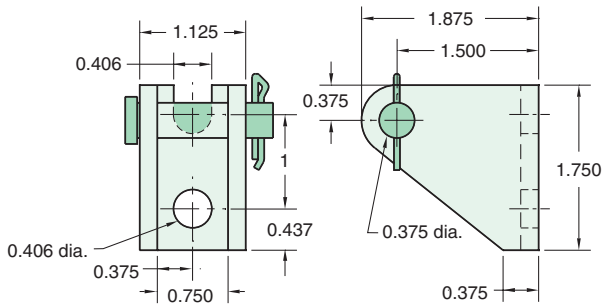

RK-3299

Replaceable Rod Seal
Material: Aluminum body

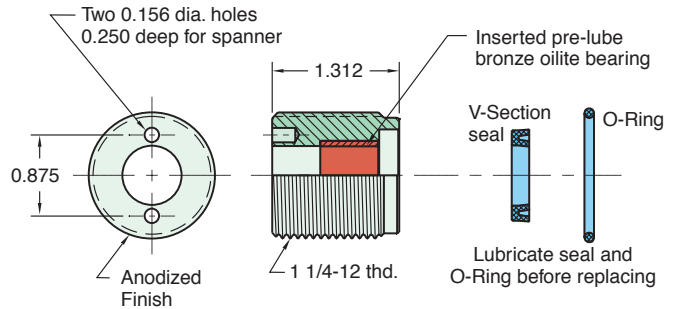

RC-3281

Rod Clevis
Material: Steel, electroless nickel plate

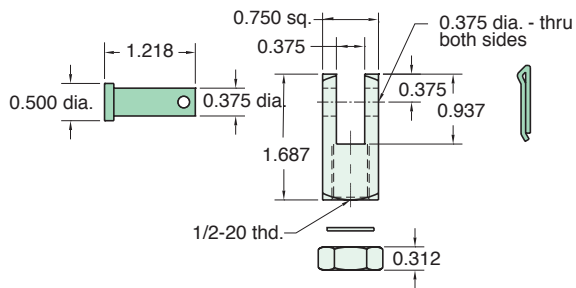

RE-3285

Rod End
Material: Steel, bright zinc plated body

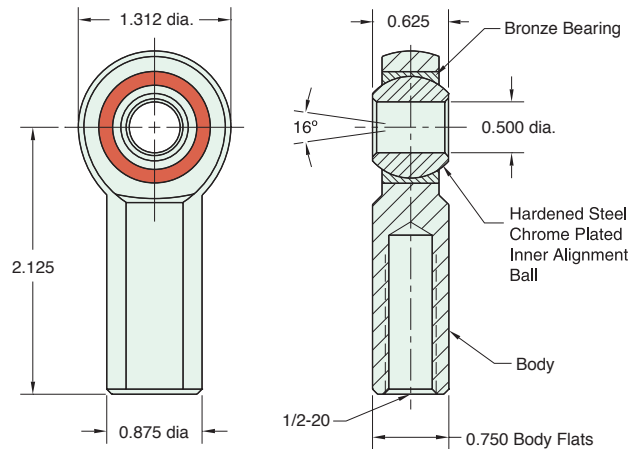

FB-3291

Foot Bracket
Material: Steel, bright zinc plated

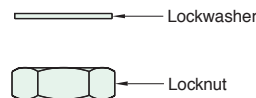
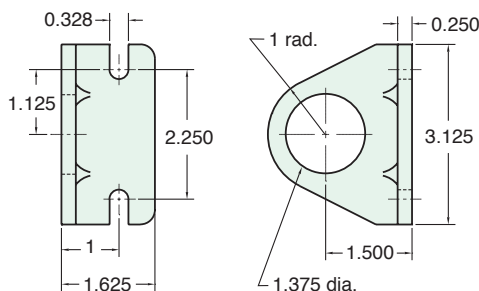

Max. Static Radial Load: 6700 lbs.
Fits Rod Thread Size: 1/2-20